

Assemble the Robot Step by Step

**--on Production
(The Four-wheel car)**

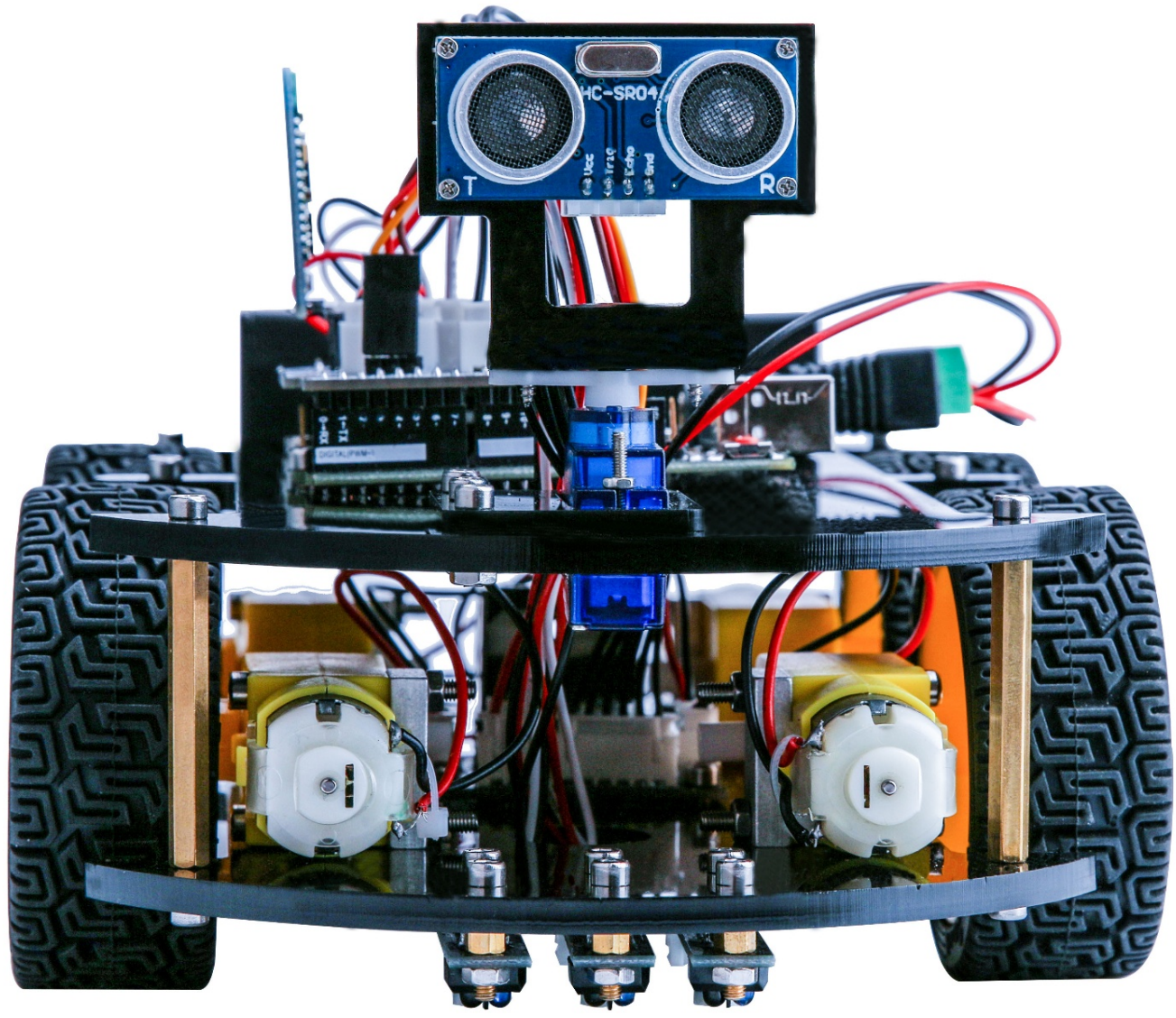

Preface

Our Company

Established in 2011, Elegoo Inc. is a professional manufacturer and exporter that specializes in the design, development production and marketing of Arduino, 3d printers, raspberry pi and STM32. We are located in Shenzhen which is known as China Silicon Valley. All of our products comply with international quality standards and are greatly appreciated in a variety of different markets throughout the world.

Our official website is: [Http://www.elegoo.com](http://www.elegoo.com)

Our USA amazon shop is: [Http://www.amazon.com/shops/A2WWHQ25ENKVJ1](http://www.amazon.com/shops/A2WWHQ25ENKVJ1)

Our Tutorial

The tutorial is for beginners. In the tutorial, you can learn how to use Arduino controller board, sensors and components. You can also learn the basic knowledge of all the parts. But if you want to study Arduino systematically, we recommend you to buy the book "Arduino Cookbook" which is written by Michael Margolis.

This Tutorial

This tutorial will show you how to assemble the car and offer you the basic program to make all the function come true.

If you want to learn more than the tutorial, Google would be a great place to learn.

Our after-sales

If you have any questions or suggestions about our company, product or tutorial. Please drop us a line at service@elegoo.com (US and CA customers) or EUservice@elegoo.com (Europe Customers)

We appreciate all your critical advices and will do our very best to meet your expectation.

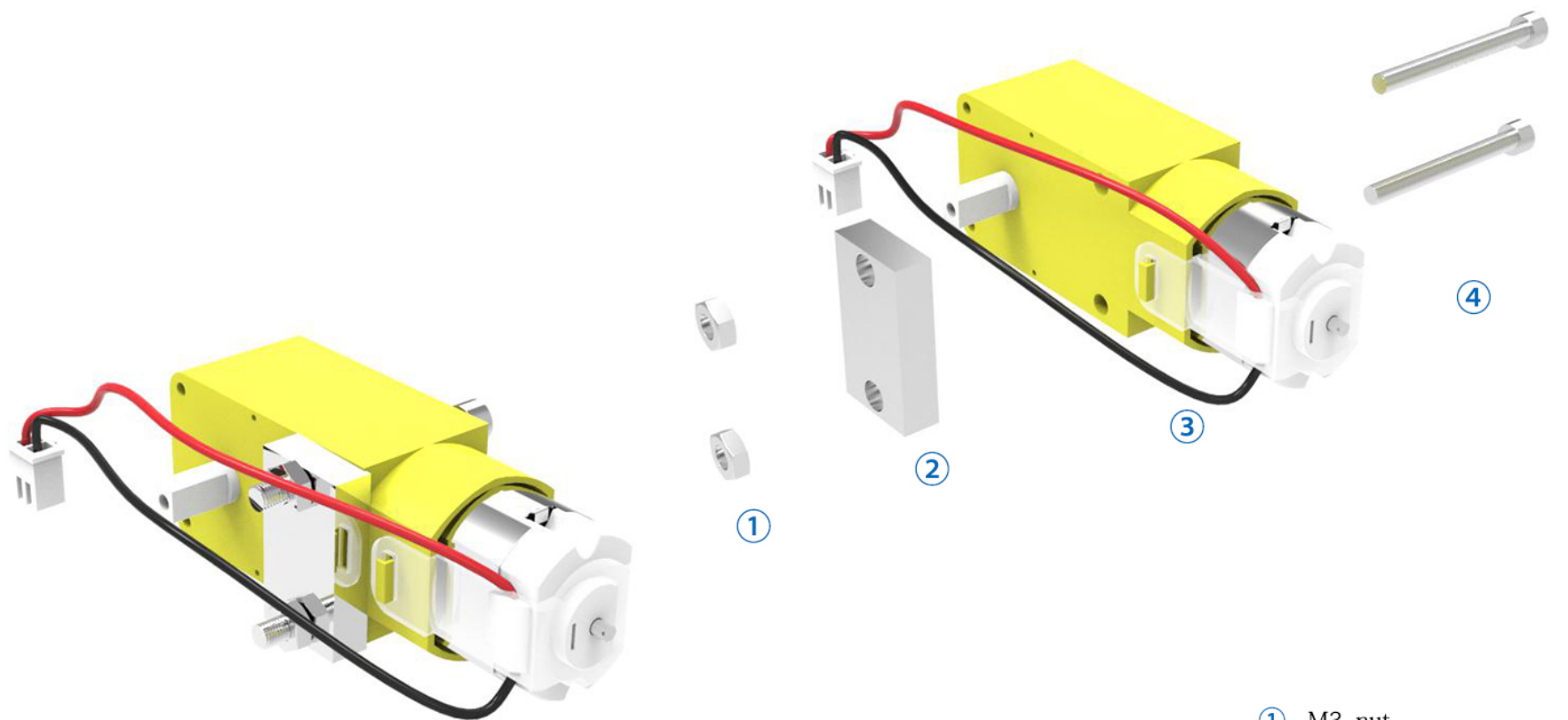

Pay attention: Two of the motors are assembled as above.

- ① M3 nut
- ② Aluminium Block
- ③ DC speed motor
- ④ M3 hex screws 3*30mm

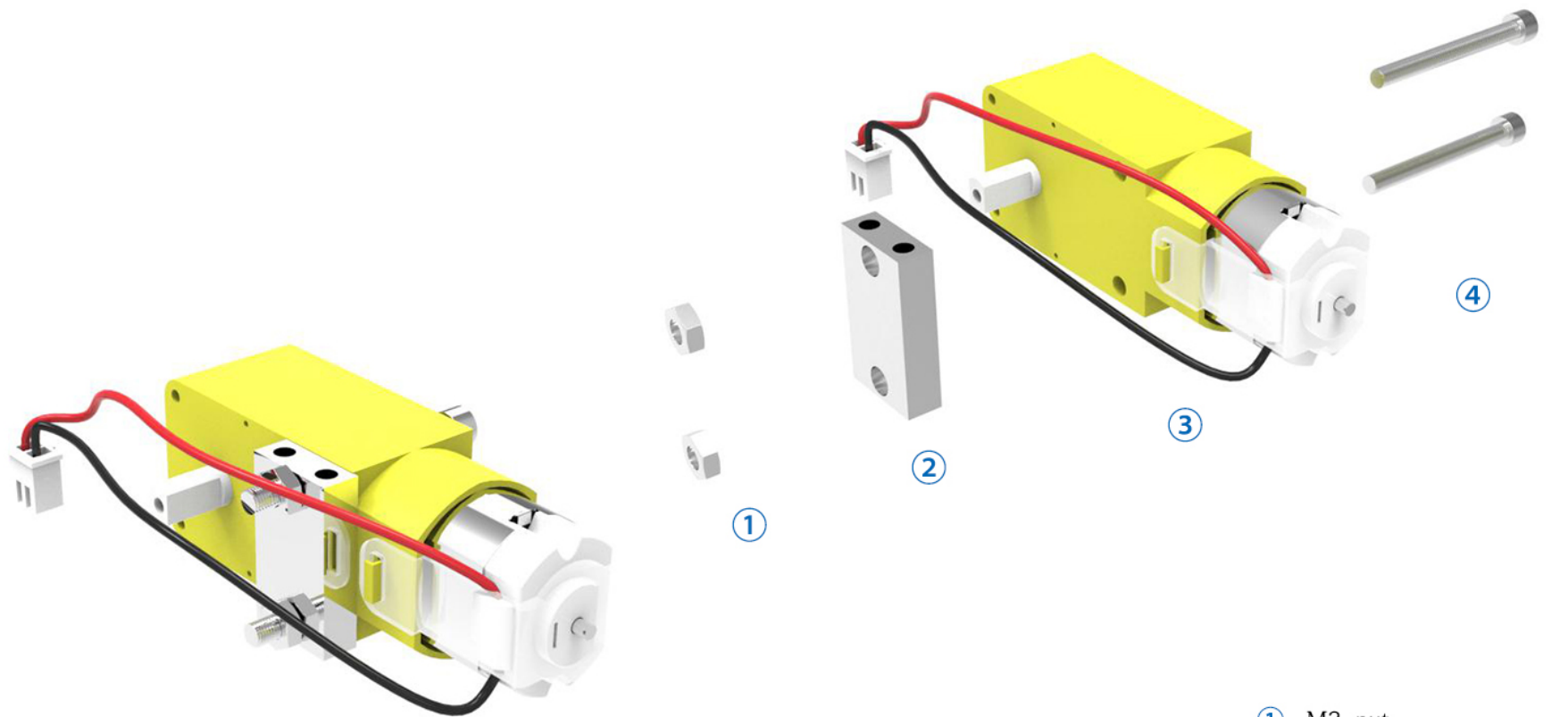

Pay attention: Two of the motors are assembled as above.

- ① M3 nut
- ② Aluminium Block
- ③ DC speed motor
- ④ M3 hex screws 3*30mm

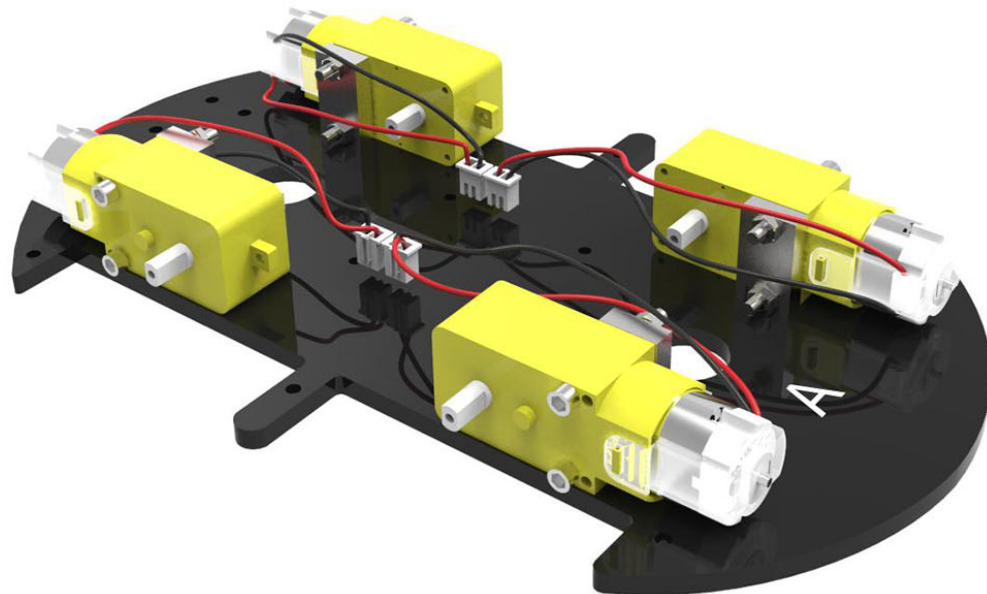
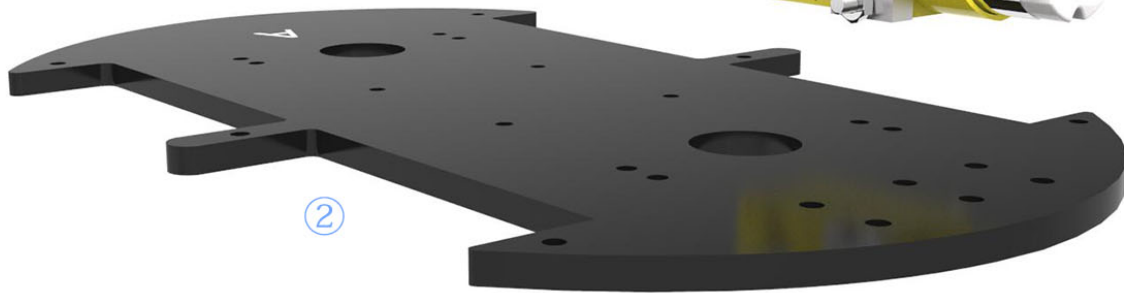
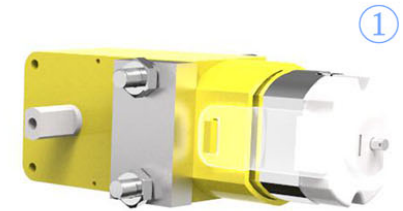

- ① Motor units
- ② Acrylic plate
- ③ M3 hex screws 3*10mm

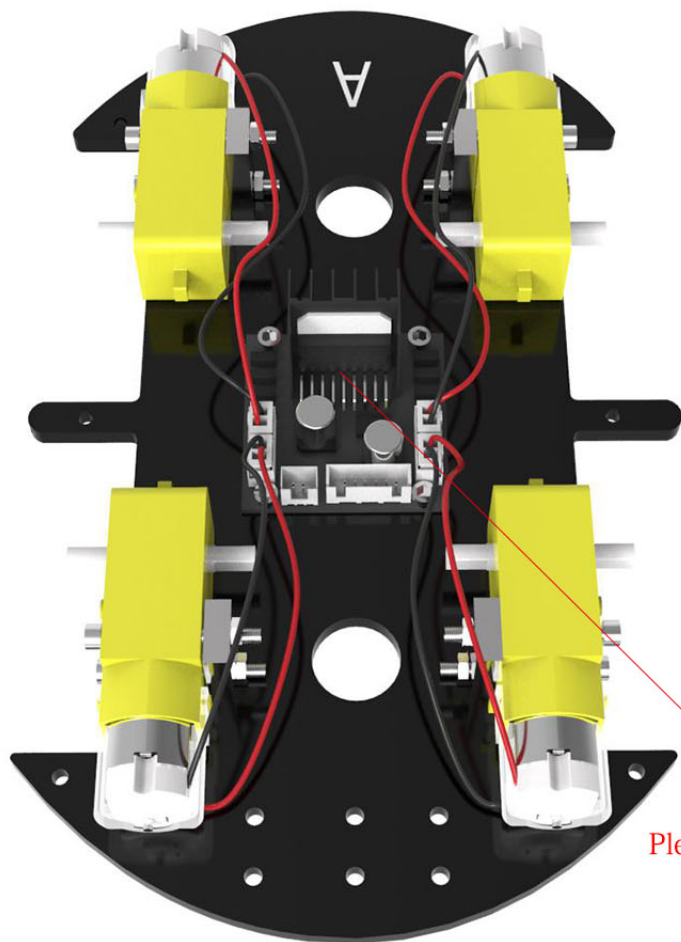

Please pay attention to the direction of L298N module.

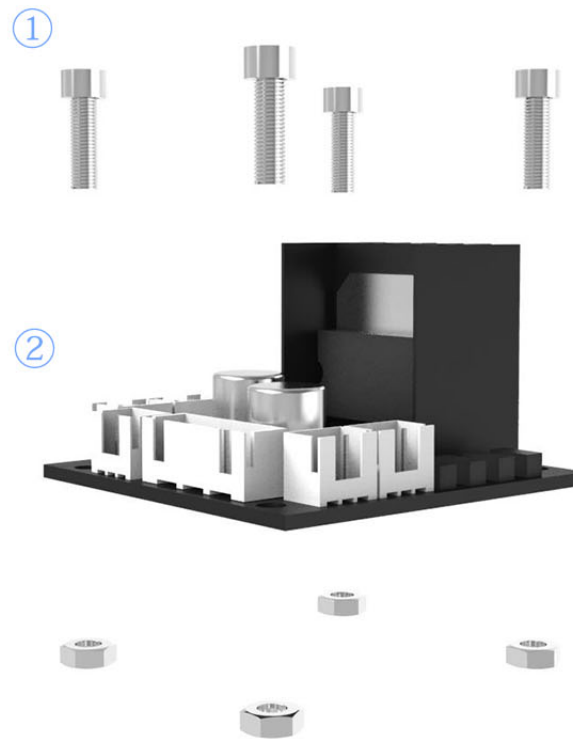

- ① M3 hex screws 3*12mm
- ② L298N
- ③ M3 nut

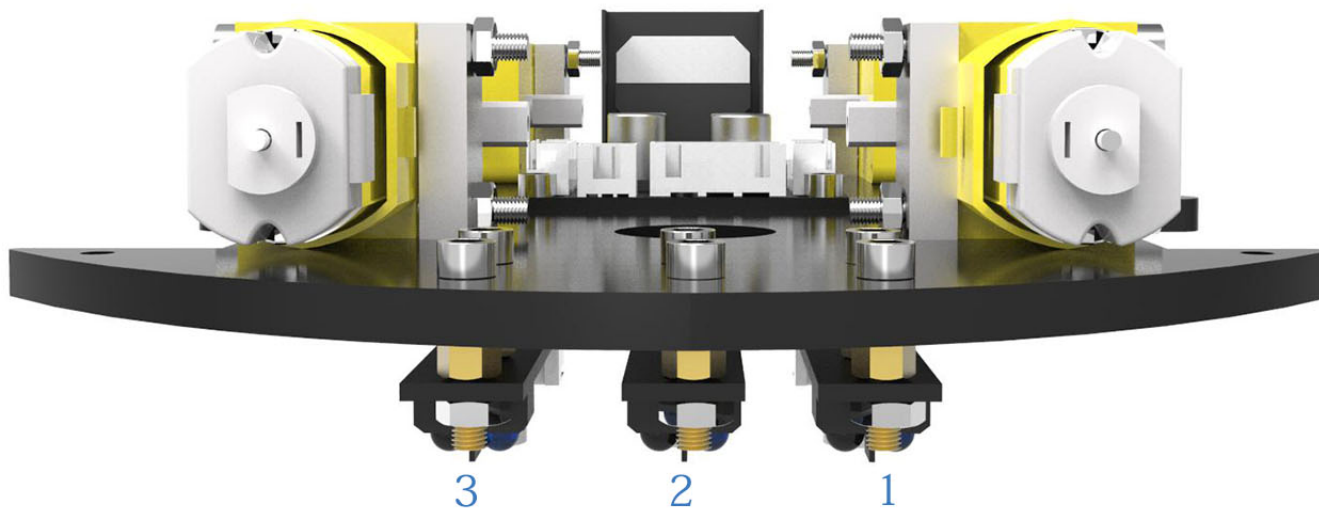
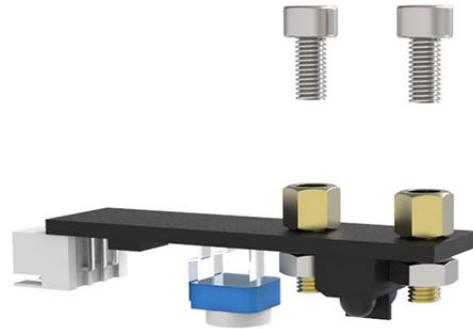

- ① M3 hex screws 3*7mm
- ② 3*4+6 copper
- ③ Line tracking module
- ④ M3 nut

Please be noted to assemble them as above.

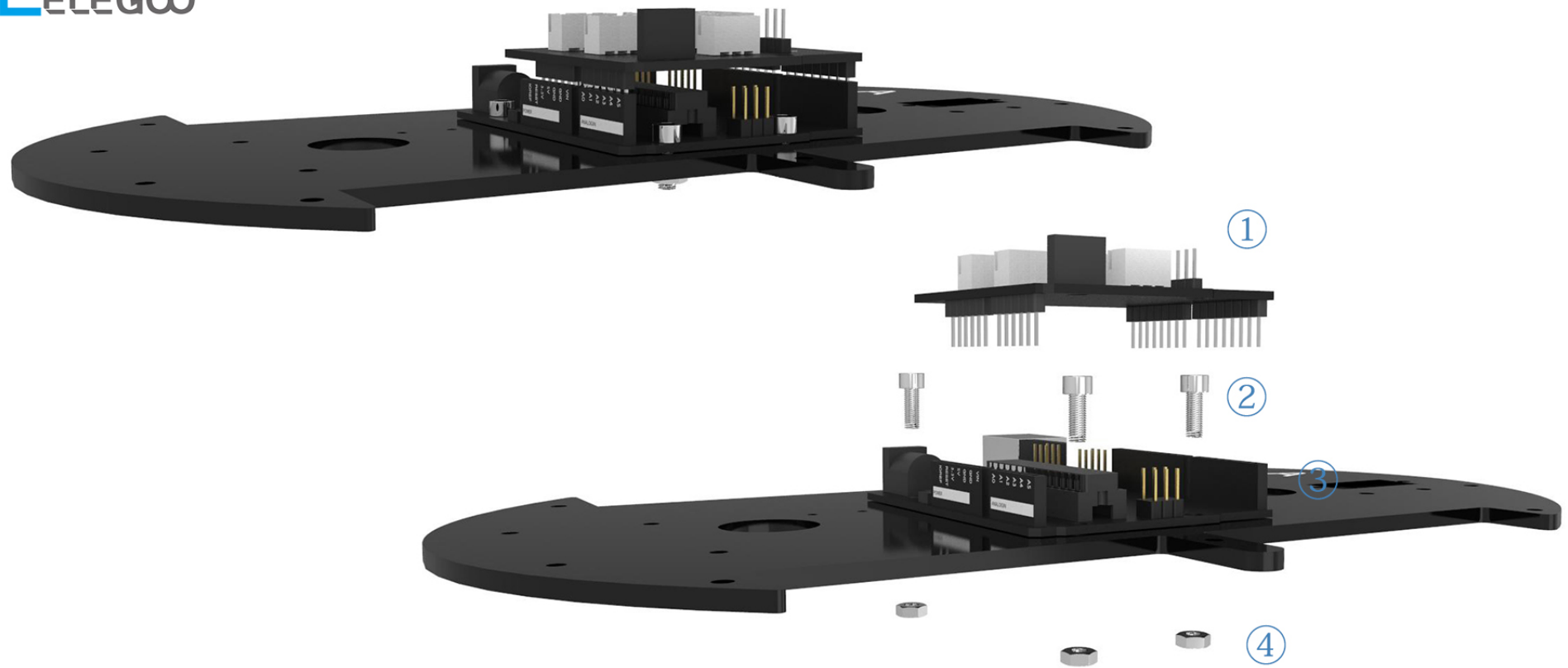

- ① Sensor board V5.0
- ② M3 hex screws 3*12mm
- ③ UNO R3 board
- ④ M3 nut

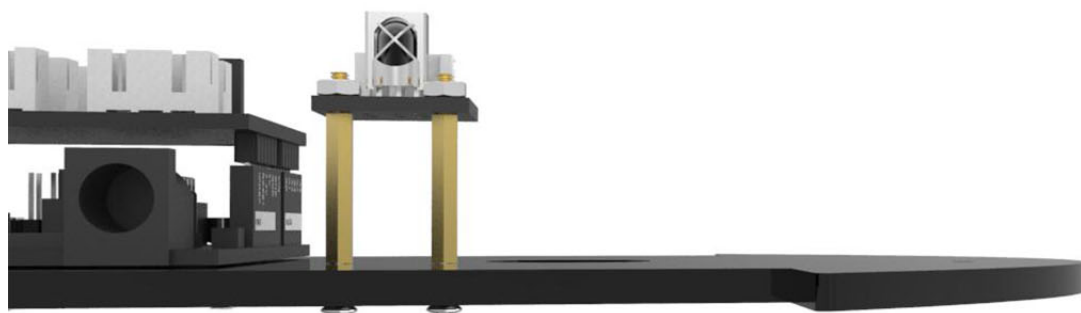

- ① M2 nut
- ② Infrared receiver module
- ③ 2*15+4 copper
- ④ M2 cross screws 2*10mm

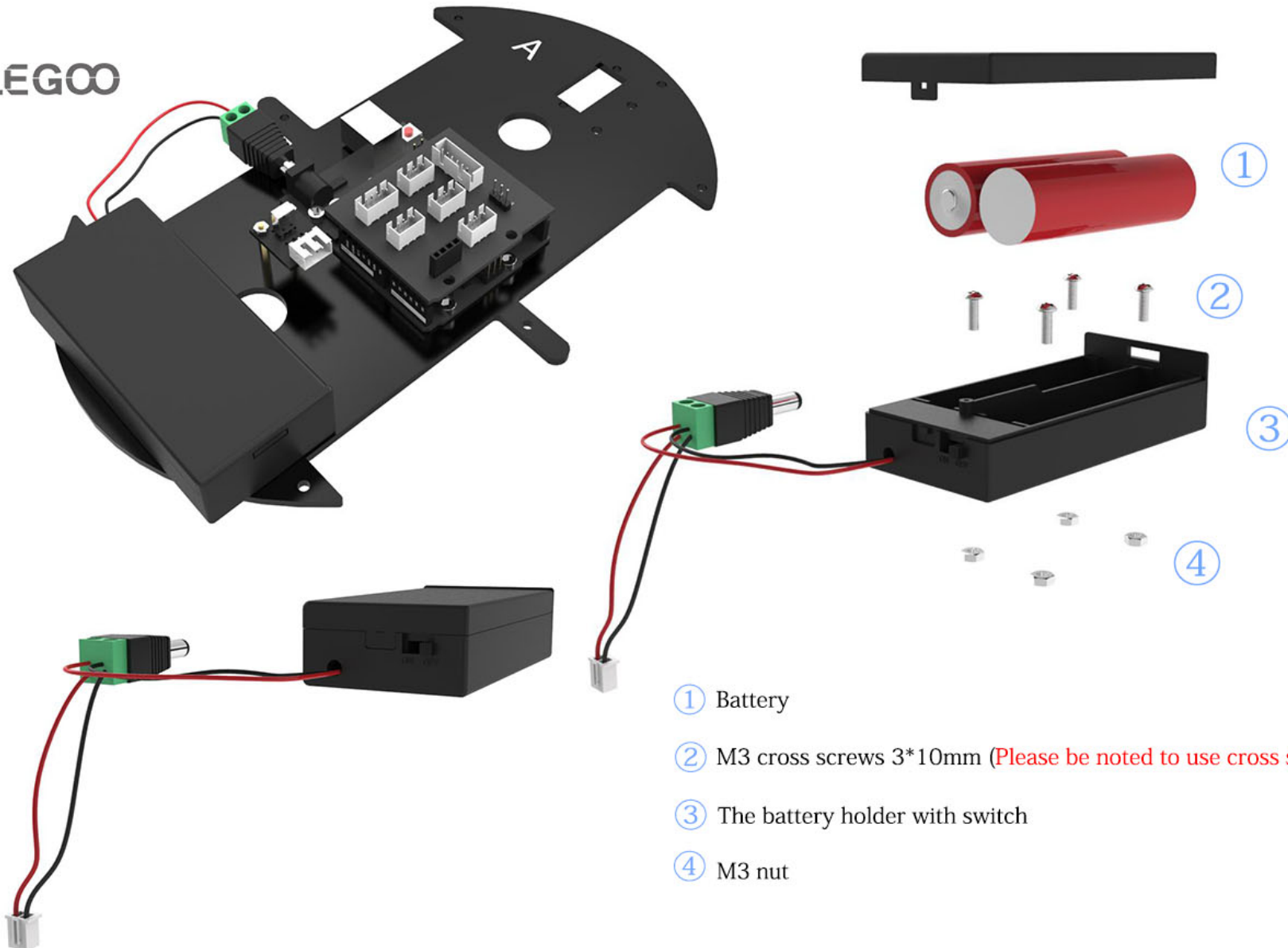

- ① Battery
- ② M3 cross screws 3*10mm (Please be noted to use cross screws)
- ③ The battery holder with switch
- ④ M3 nut

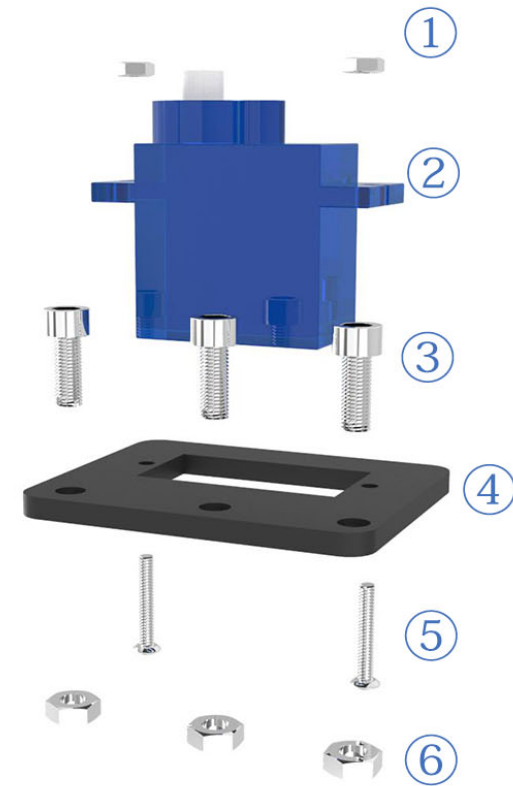
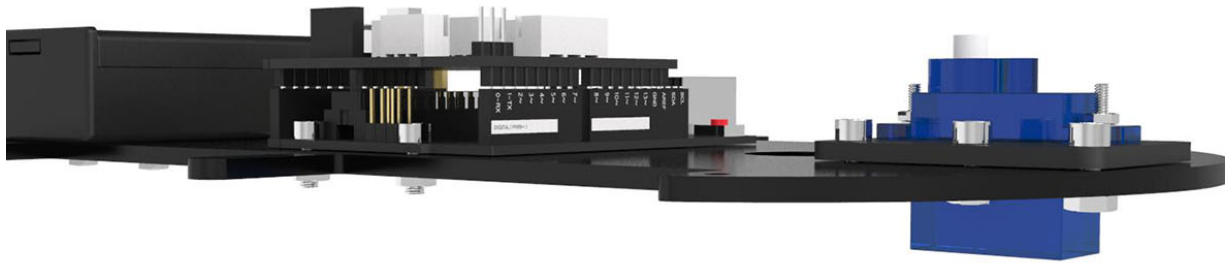

- ① M2 nut
- ② SG90
- ③ M3 hex screws 3*10mm
- ④ Holder board
- ⑤ M2 cross screws 2*10mm
- ⑥ M3 nut

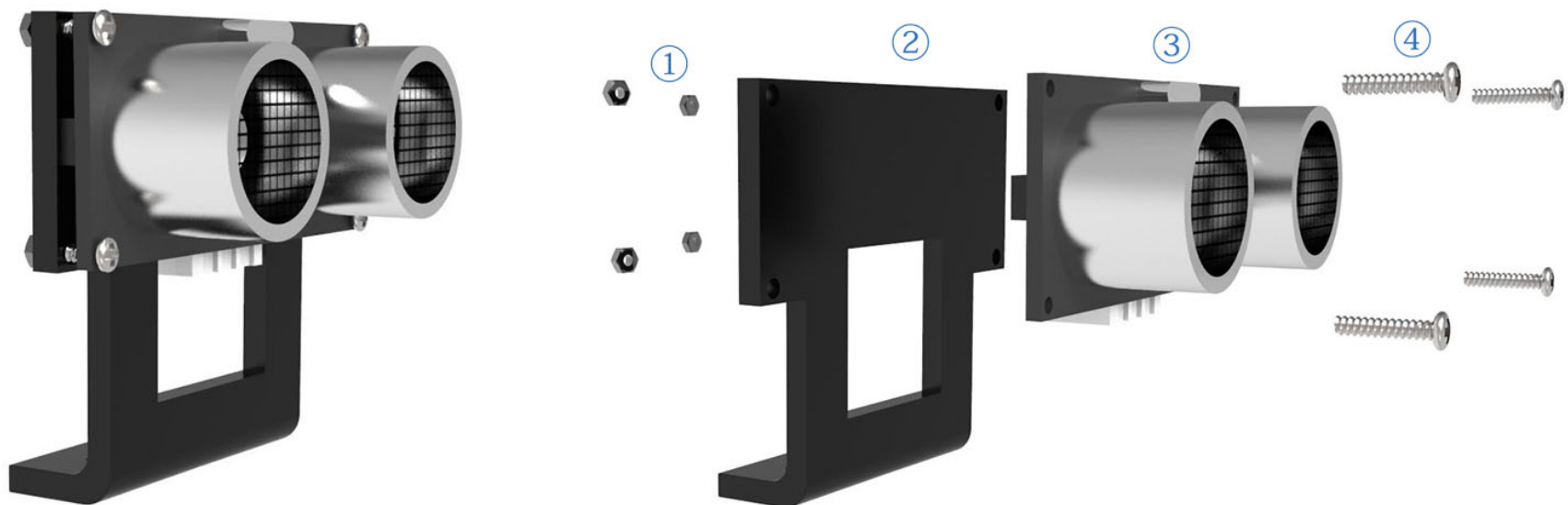

- ① M1.6 nut
- ② The acrylic ultrasonic pan-tilt holder
- ③ The ultrasonic module
- ④ M1.6 cross screws 1.6*8mm

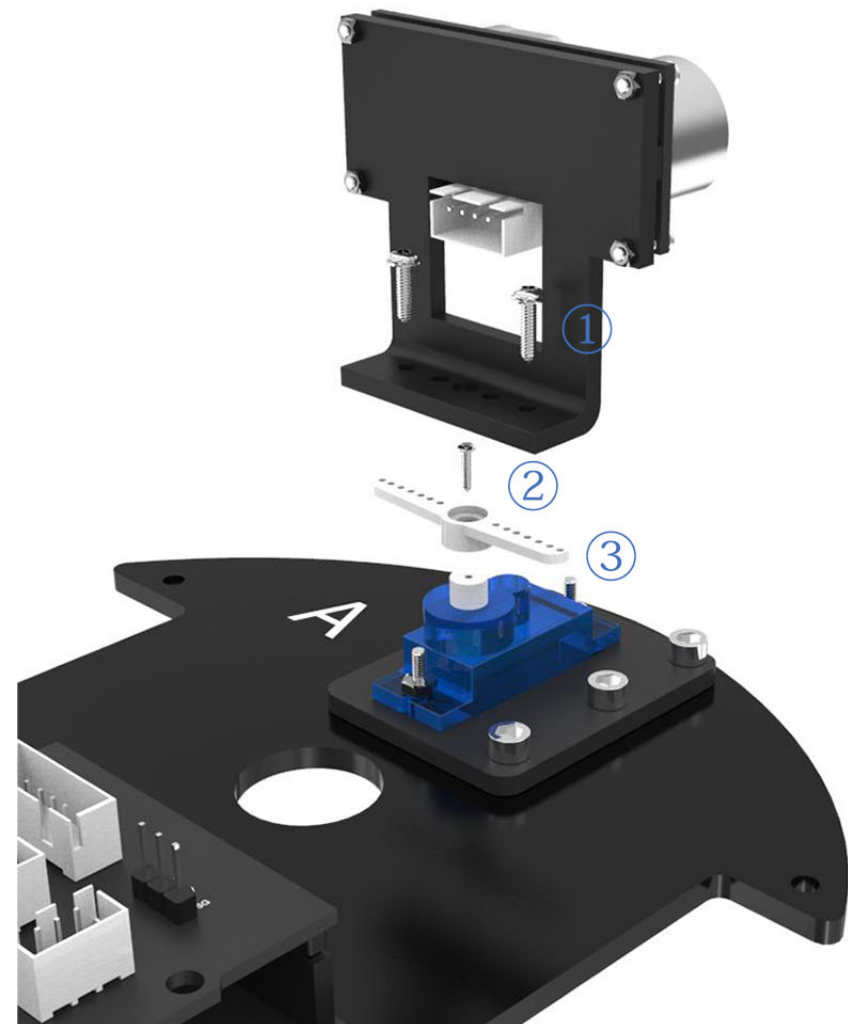
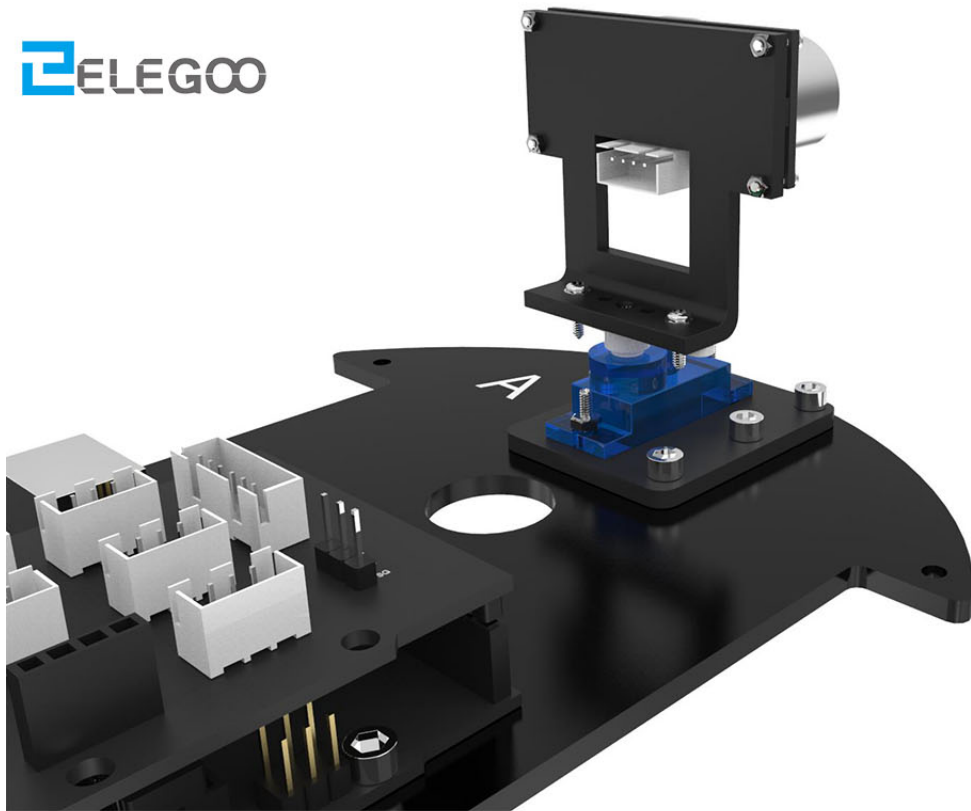

- ① Self-tapping screw
- ② Mini self-tapping screw
- ③ Fastening board

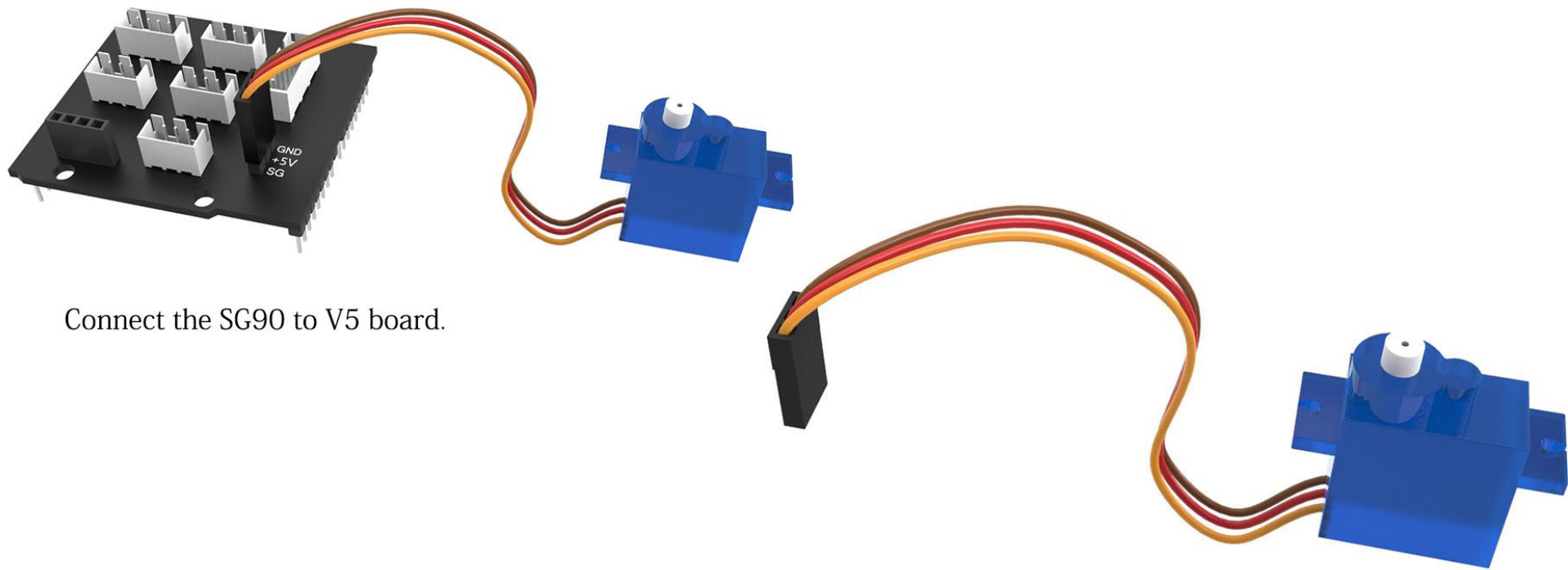

Connect the SG90 to V5 board.

Connect The IR Module to V5 Board.

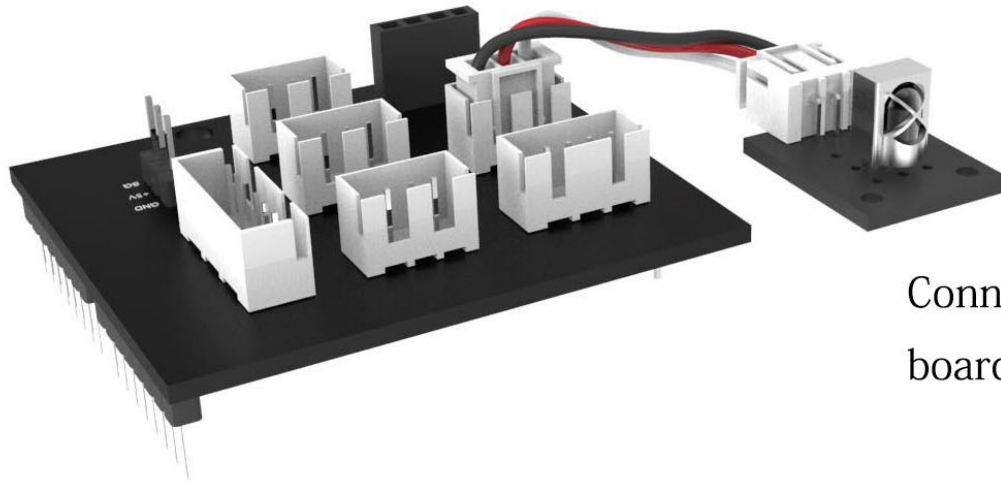
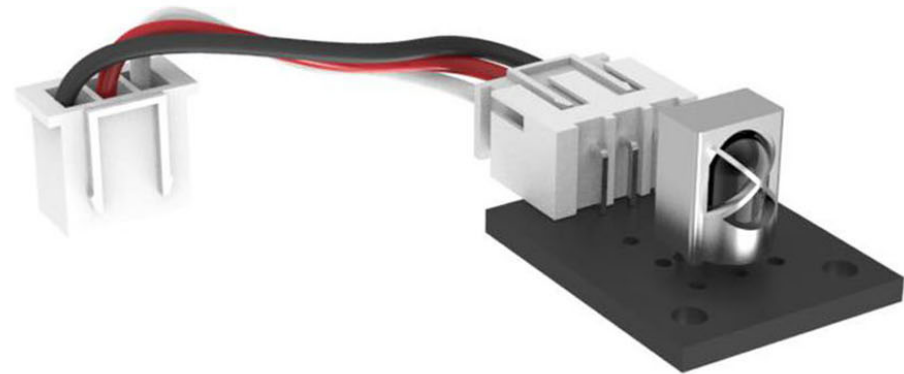

Connect the infrared receiver module to the expansion board with the DuPont lines.

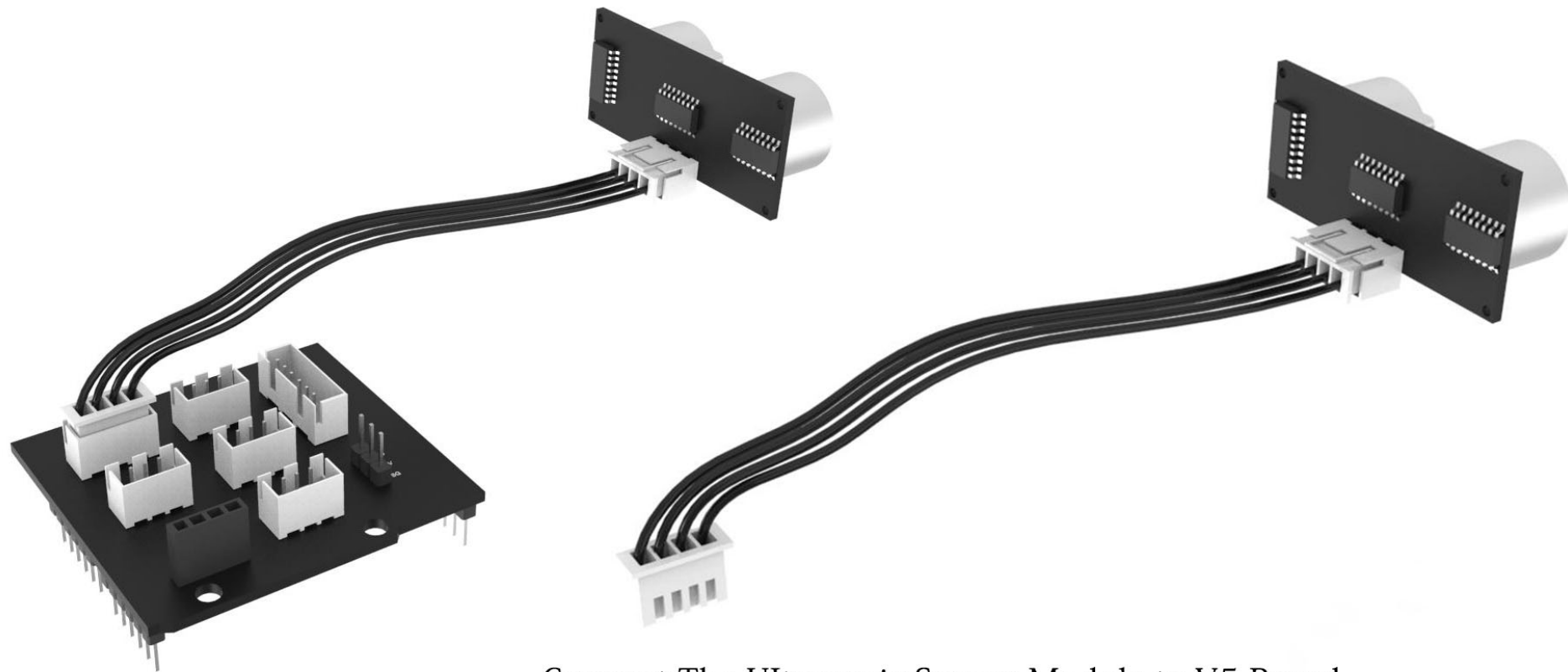

Connect The Ultrasonic Sensor Module to V5 Board.

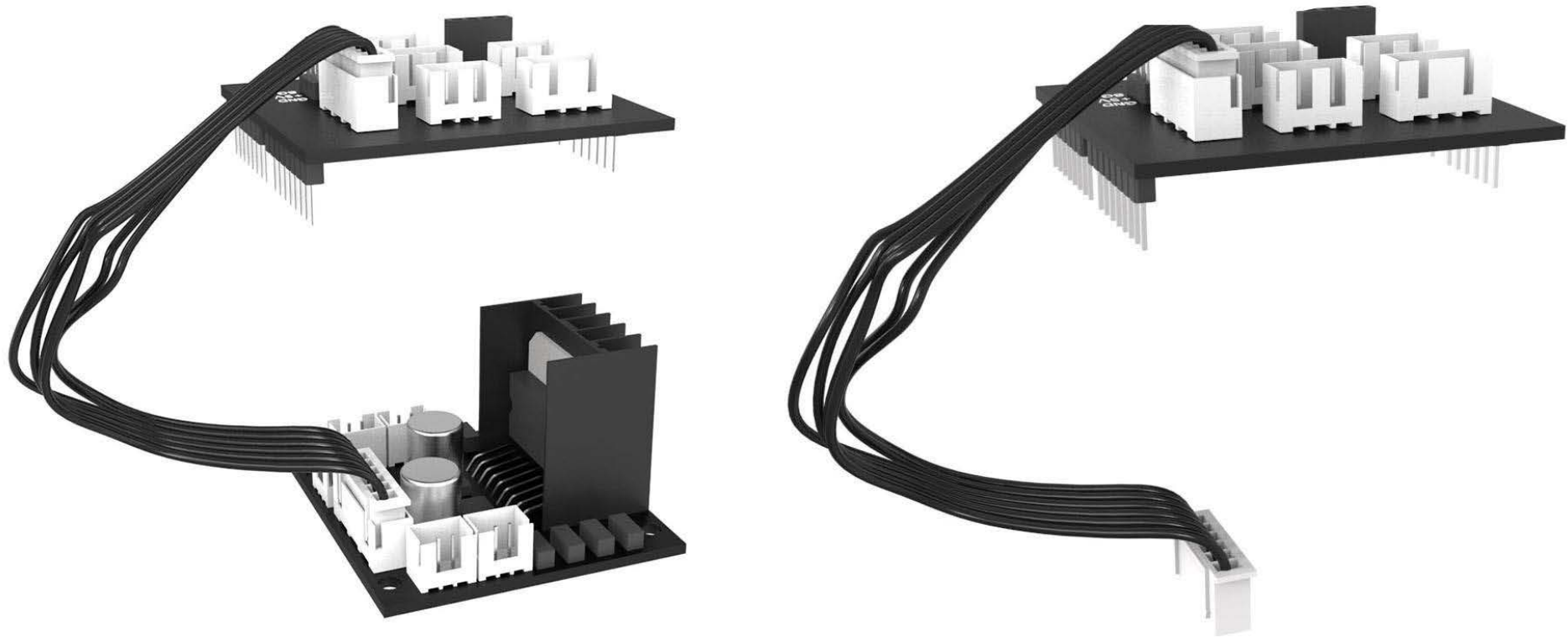

Connect the L298N board to V5 board.



Connect The Battery Box to The L298 Board.

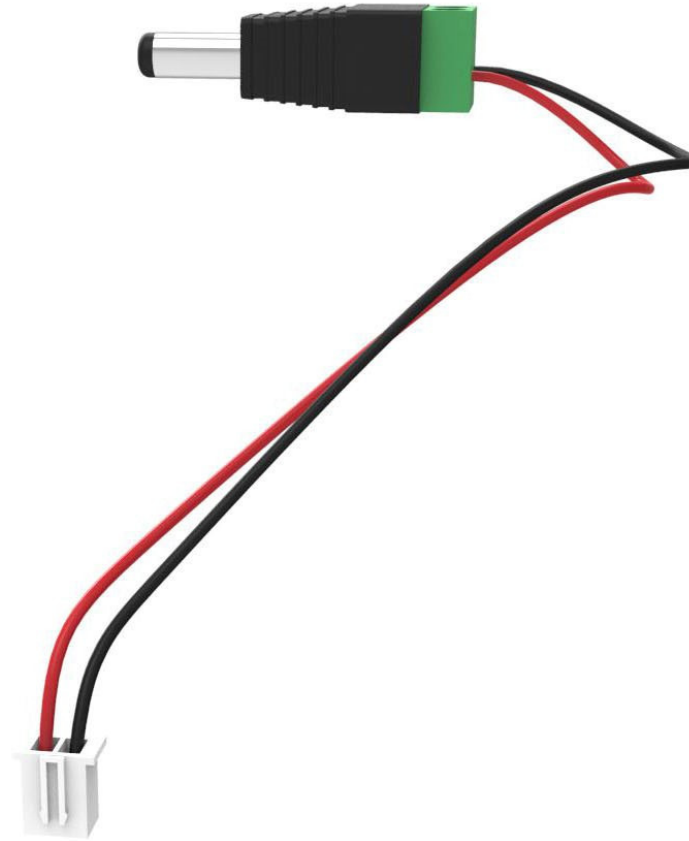
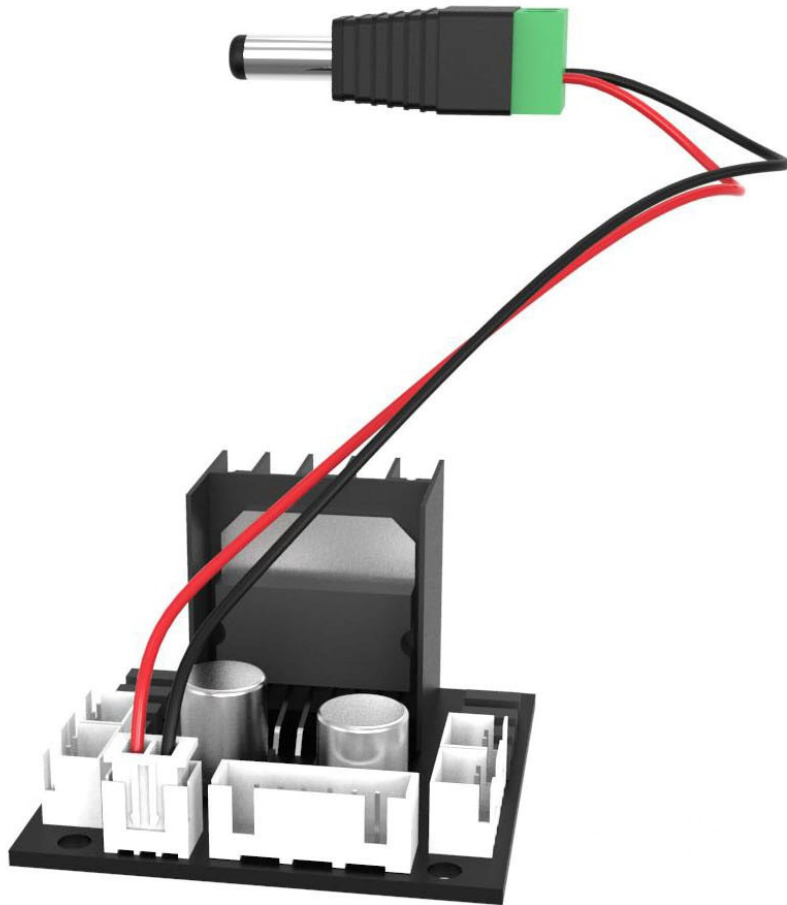

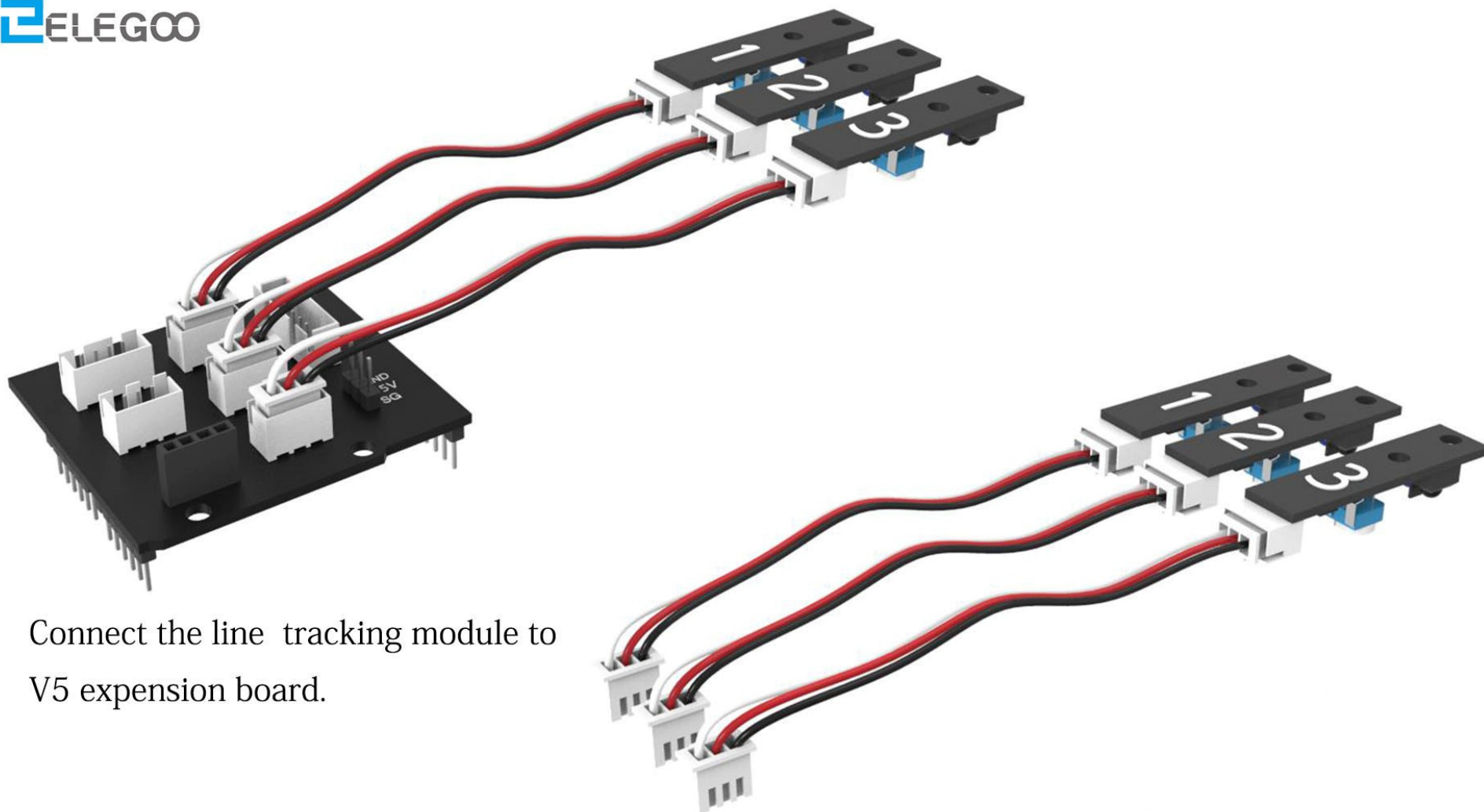

Connect the line tracking module to V5 expansion board.



① bluetooth module

Attention: The bluetooth module should be pulled out before you upload the program every time, or it will be failed to upload the program.

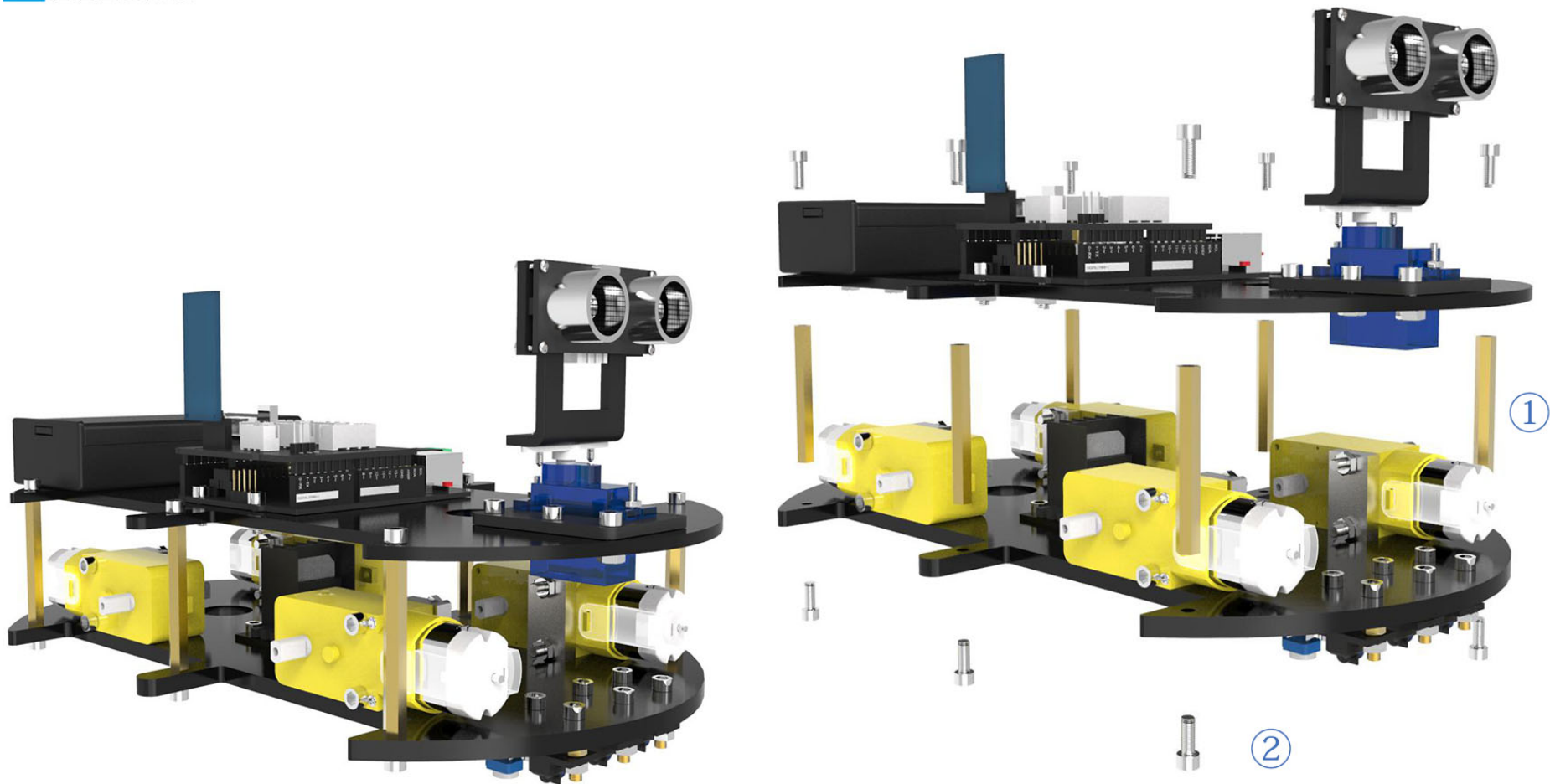

- ① 3*40 copper column
- ② M3 hex screws 3*10mm

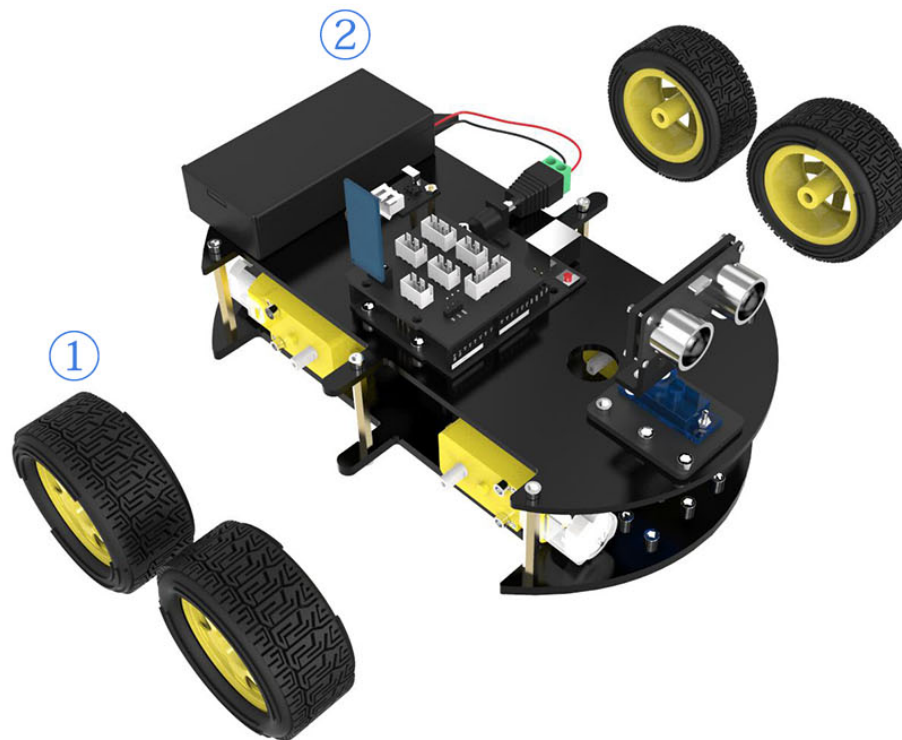
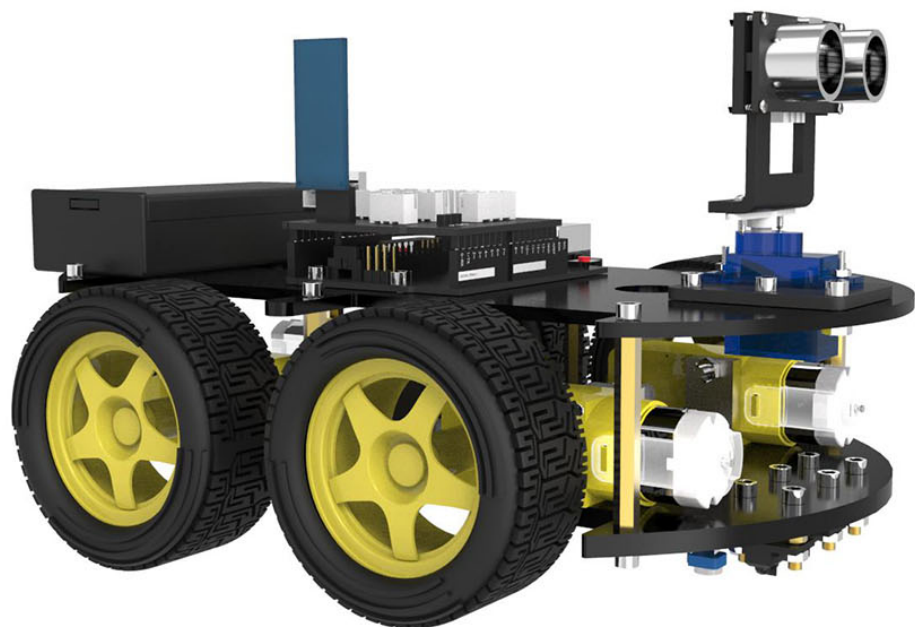

- ① Tires
- ② The main body

3、 Summary

This tutorial is aimed at making it easier to assemble the car and if you find any problems or have any suggestions for the tutorial or the robot car please feel free to send us an email at service@elegoo.com (US and CA customers) or EUservice@elegoo.com Europe customers).

After assembling and connecting all the components, we need to debug some basic programs of the car, which we will learn in the next lesson.